

**BROOKVENT**<sup>TM</sup>

**aircycle**   
ONE PRO



# Aircycle ONE PRO SRHR Single Room Heat Recovery System



Retrofit



 **RIGHT PRODUCTS  
BEST ADVICE**

## Description

The **Aircycle ONE PRO wall-mounted heat recovery unit** is a modern solution designed to ensure air exchange while recovering thermal energy. The device provides ventilation and reduces air pollution and humidity levels in rooms. The device operates in reverse mode, recovering heat in a ceramic exchanger.

**Designed for installation in external walls with a thickness of 300–570 mm.**

## Features

- ✓ **Aesthetic front cover**, easy to remove for cleaning without tools
- ✓ **Dust filter removable from inside** the room for maintenance
- ✓ **Regenerative heat exchanger** with ceramic core
- ✓ **High thermal efficiency up to 95%**
- ✓ **Low power consumption**
- ✓ **LED indicating operation** and the need to replace the filter
- ✓ **No need to drain condensate**
- ✓ External grille made of **high-quality ABS plastic**
- ✓ **High-efficiency** bidirectional brushless EC motor
- ✓ Motor equipped with **ball bearings**
- ✓ **Double insulated device**: no earthing required
- ✓ Free cooling mode
- ✓ Degree of protection **IPX4**
- ✓ Power supply 230V~ 50Hz

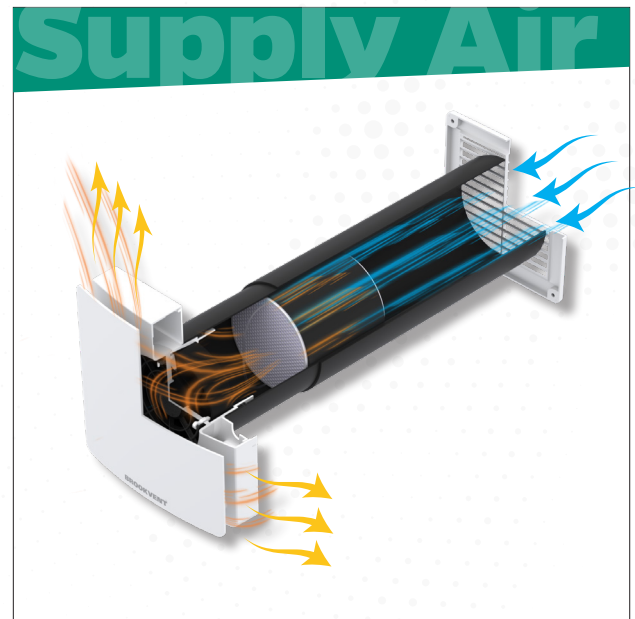
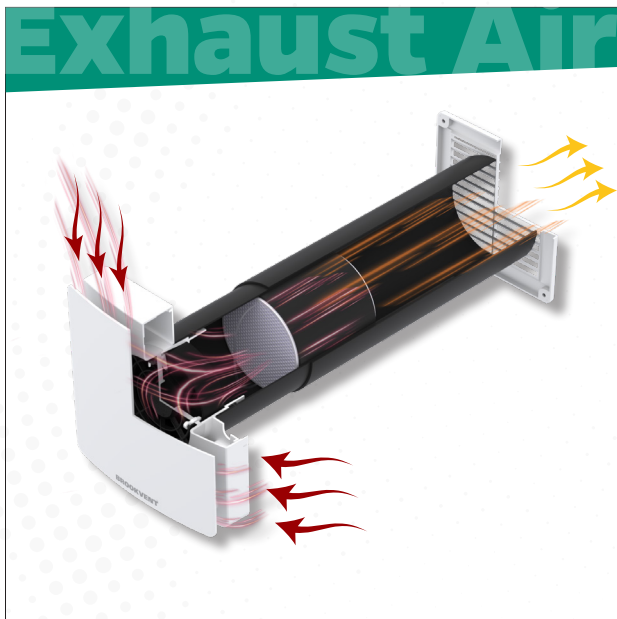

### Modern, energy-efficient Aircycle ONE PRO single room heat recovery unit

ensures a healthy microclimate in the home. It operates in alternating supply and exhaust mode, using a ceramic exchanger for heat accumulation and recovery, which reduces heat loss and lowers heating costs. It ensures constant air exchange, removes moisture, odours and pollutants, protecting against the growth of mould and fungi.

### Ideal for:

- ✓ living rooms
- ✓ bedrooms
- ✓ dining rooms
- ✓ basements
- ✓ corridors
- ✓ attics

**The wall-mounted recuperator is equipped with a ceramic heat exchanger** with a honeycomb structure, which heats up under the influence of exhaust air and supplies fresh air from outside. The device housing is made of high-quality ABS plastic.

**The device has a filter**, that enables quick cleaning and maintenance.

**Aircycle ONE PRO** devices are characterised by IPX4 protection and protection class II. The device is designed for indoor use only.



**Compact form, optimal efficiency.**

**aircycle**  
ONE PRO

### Technical specifications

Parameter	Aircycle ONE PRO 150
Energy Class of the Device	A
Unit Type	Residential two-way
Type of control	Three speed
Average Heat Recovery Efficiency [%]	83,9*
Maximum air flow [m <sup>3</sup> /h]	60
Power consumption at maximum flow [W]	3,3
LpA** Sound pressure level (dBA) at a distance of 3 m. Applies to gears I/II/III	10/20/26
Unit power consumption [W/m <sup>3</sup> /h]	0,058
Airflow at speed I/II/III [m <sup>3</sup> /h]	20/42/60
Power consumption at speed I/II/III [W]	1,7/2,5/3,3
Average thermal efficiency at speed I/II/III [%]	87/83,9/80,3
IP protection rating	X4

\* For reference speed II

\*\*For comparison purposes only

### Synchronisation

Synchronisation can be wired (recommended) or via the 50 Hz mains frequency.

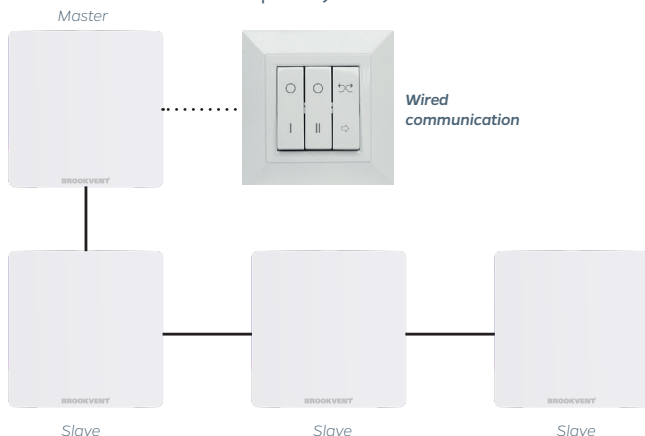

Wired synchronisation diagram.

### Dimensions

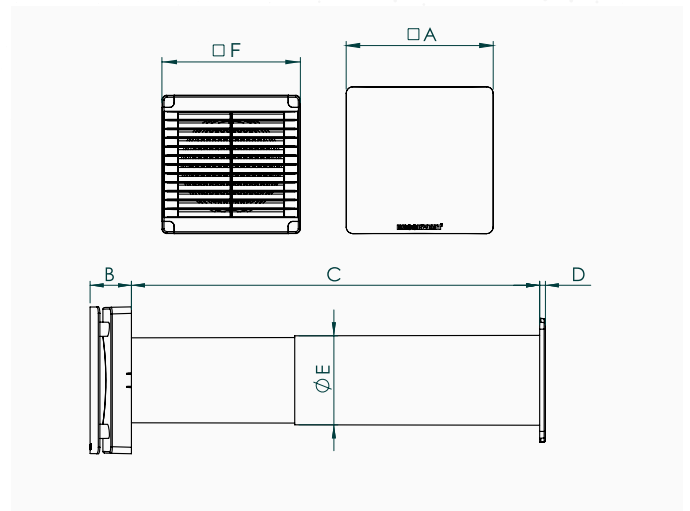

All dimensions are given in millimetres.

Name	□A	B	C	D	∅E	□F
Aircycle ONE PRO 150	220	54	300-570	7	159	202

### Control (optional)

Optional user control for operating up to 10 devices.



### Product code

Model	Code
Aircycle ONE PRO 150	212000400

